

Reg. No. :

--	--	--	--	--	--	--	--	--	--	--	--	--	--	--	--	--	--	--	--

Question Paper Code : 73444

B.E./B.Tech. DEGREE EXAMINATION, APRIL/MAY 2017.

Third Semester

Electronics and Communication Engineering

EC 2205/EC 36/080290011 — ELECTRONIC CIRCUITS — I

(Common to Medical Electronics Engineering)

(Regulations 2008)

Time : Three hours

Maximum : 100 marks

Answer ALL questions.

PART A — (10 × 2 = 20 marks)

1. Mention the factors that affect BJT biasing.
2. Why thermal runaway is not present in FET?
3. State miller's theorem.
4. Why RC coupling is the most widely used coupling between two stages of a cascaded amplifier?
5. What is alpha cutoff frequency?
6. Define rise time and sag in an amplifier.
7. How an voltage amplifiers is different from power amplifiers?
8. List the use of heat sink.
9. Calculate the ripple of a capacitor filter for a peak rectified voltage of 30V, capacitor $c = 50 \mu F$ and a load current of 50mA.
10. What is the need of fold back current limiting?

PART B — (5 × 16 = 80 marks)

11. (a) (i) Prove that the operating point in a potential divider biasing circuit is independent of β . Neglect V_{BE} compared to equivalent voltage levels involved in the circuit. (10)

(ii) Determine the dc level of I_B and V_C for the network of figure, 1: (6)

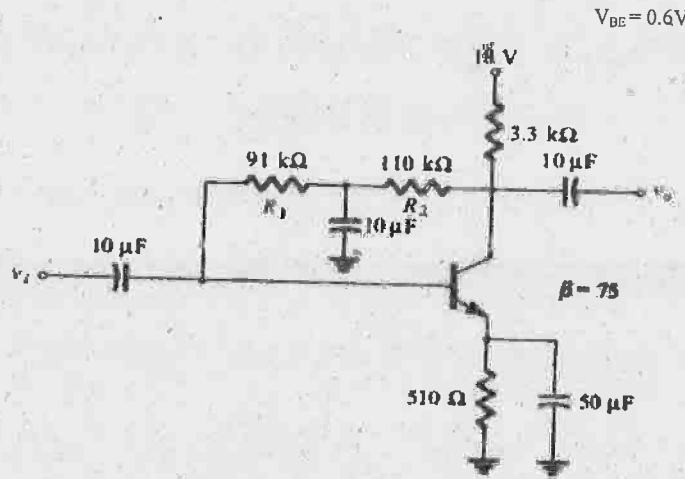

Figure 1

Or

(b) (i) State the need of compensation. And with the circuit diagram, explain how compensation is accomplished for variations in base-emitter voltage due to temperature variations. (8)

(ii) Determine the following for the network of Figure.2: (8)

(1) I_{DQ} , V_{GSQ}

(2) V_D

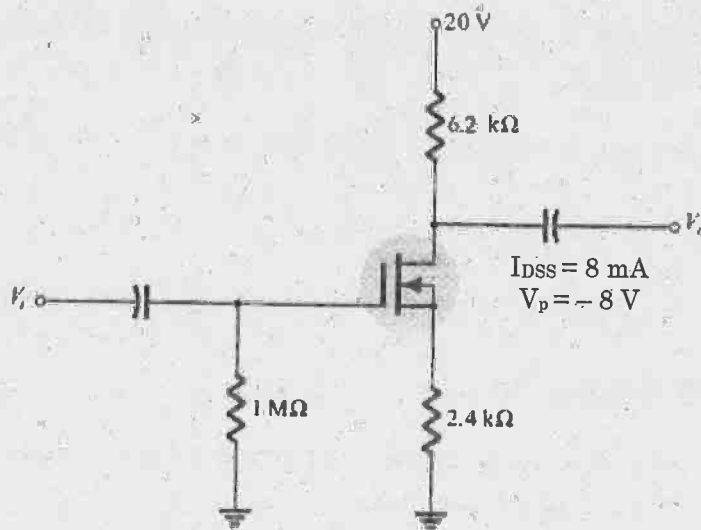

Figure.2

12. (a) For the common-base amplifier of figure. 3, determine the following parameters using the complete hybrid equivalent model and compare the results to those obtained using the approximate model. (16)

- i. Z_i
- ii. A_i
- iii. A_v
- iv. Z_o

$$h_{ie} = 1.6 \text{ k}\Omega \quad h_{fe} = 110$$

$$h_{re} = 2 \times 10^{-4} \quad h_{re} = 20 \text{ }\mu\text{S}$$

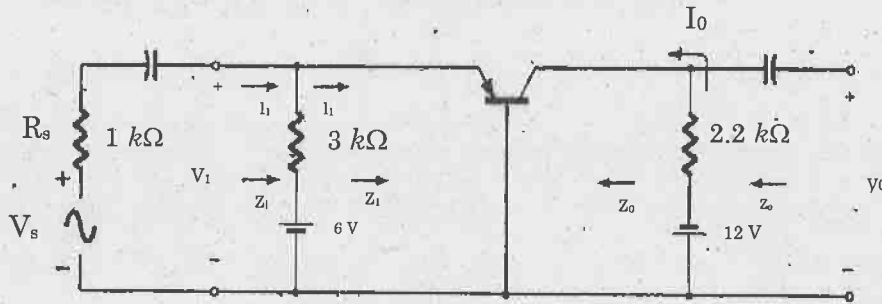

Figure.3

Or

- (b) (i) Suggest and brief the techniques to improve the input impedance of the transistor circuits. (12)
- (ii) For a differential amplifier the two input signals are $V_1 = 100 \text{ }\mu\text{V}$ and $V_2 = -100 \text{ }\mu\text{V}$. Calculate the values of differential input signal and common mode input signal. If the values of differential and common mode gains are 2500 and 0.5 respectively. Calculate V_0 and CMRR in dB. (4)

13. (a) (i) Discuss the effect of emitter by pass capacitor on low frequency response of BJT amplifier. (8)

- (ii) The following low frequency parameters are known for a given transistor at $I_c = 1.3 \text{ mA}$, $V_{CE} = 10 \text{ V}$ at room temperature and the h-parameters are: (8)

$$h_{fe} = 50, h_{ie} = 1100\Omega, h_{re} = 2.5 \times 10^{-4}, h_{oe} = 24 \text{ }\mu\text{A/V}$$

At the same point $f_T = 50 \text{ MHz}$ and $C_{ob} = 3 \text{ pF}$. Compute all the values of hybrid π parameters of CE transistor model.

Or

- (b) Draw the ac equivalent circuit for a source follower at high frequencies and derive expressions for voltage gain, input impedance and output admittance. Give its application also. (16)

14. (a) (i) Analyze the effects of transformer coupling on class A amplifier. (8)
(ii) A single transistor amplifier with transformer coupled load produces harmonic amplitudes in the output as, (8)

$$B_0 = 1.5mA, B_1 = 120mA$$

$$B_2 = 10mA, B_3 = 4mA$$

$$B_4 = 2mA, B_5 = 1mA$$

- (1) Determine the percentage total harmonic distortion.
(2) Assume a second identical transistor is used along with a suitable transformer to provide push-pull operation.

Or

- (b) (i) Show that maximum theoretical efficiency of a class-B push pull amplifier is 78.5%. (8)
(ii) Explain why even harmonics are not present in push pull amplifier. (8)
15. (a) (i) Explain the working of bridge rectifier. (6)
(ii) A bridge rectifier circuit has secondary voltage of $12 V_{rms}$. Assume secondary resistance and diode forward resistance to be negligible. Load resistance is 100Ω . Calculate peak load current, DC load current, rms load current and PIV across each diode. (10)

Or

- (b) Draw the block diagram of SMPS and explain its working. (16)